

# Rafter Purlins - D7+

## Contents

Application options	2
Basis of calculation	4
Definition of the structural system	5
Basic parameters	5
System	6
Loading	7
Design	8
Output & results	9
Reference literature	10

## Application options

Rafter purlins combine the functions of rafters and purlins. They are supported by trusses and run in parallel to the eaves.

### Available standards

- DIN EN 1995:2010/2013
- ÖNORM EN 1995:2009/2010/2015/2019
- NTC EN 1995:2008/2018
- BS EN 2012/2019
- PN EN 1995:2010
- EN 1995:2008/2014

The software designs

- single-span purlins,
- tie purlins and
- articulated purlins

for roofs with an inclination of up to 45°, which are loaded by self-weight, snow and wind.

The loads can be selected in accordance with EN 1991 (+NA).

The design is performed in accordance with EN 1995 (+NA) and the respective superposition regulation is considered.

The snow and wind loads as per EN 1991 (+NA) can be defined by selecting a climatic zone specific to the respective country or by selecting a municipality in Germany, for instance. The loads are automatically assigned to action groups.

In the output, the actions, the combinations of actions and the results are presented in detail for each load case and each load case combination.

The decisive verifications of the load-bearing capacity and the serviceability complete the output documentation.

The verifications of the fasteners are performed in accordance with EN 1995 (+NA) and are also included in the output.

### Tie purlin

Currently, systems with equal span lengths exposed to uniformly distributed loads can be calculated.

Available fasteners for the design of the tie points:

- Nails (round wire nails and plain-shank nails as well as special nails with profiled shanks)
- Special dowels

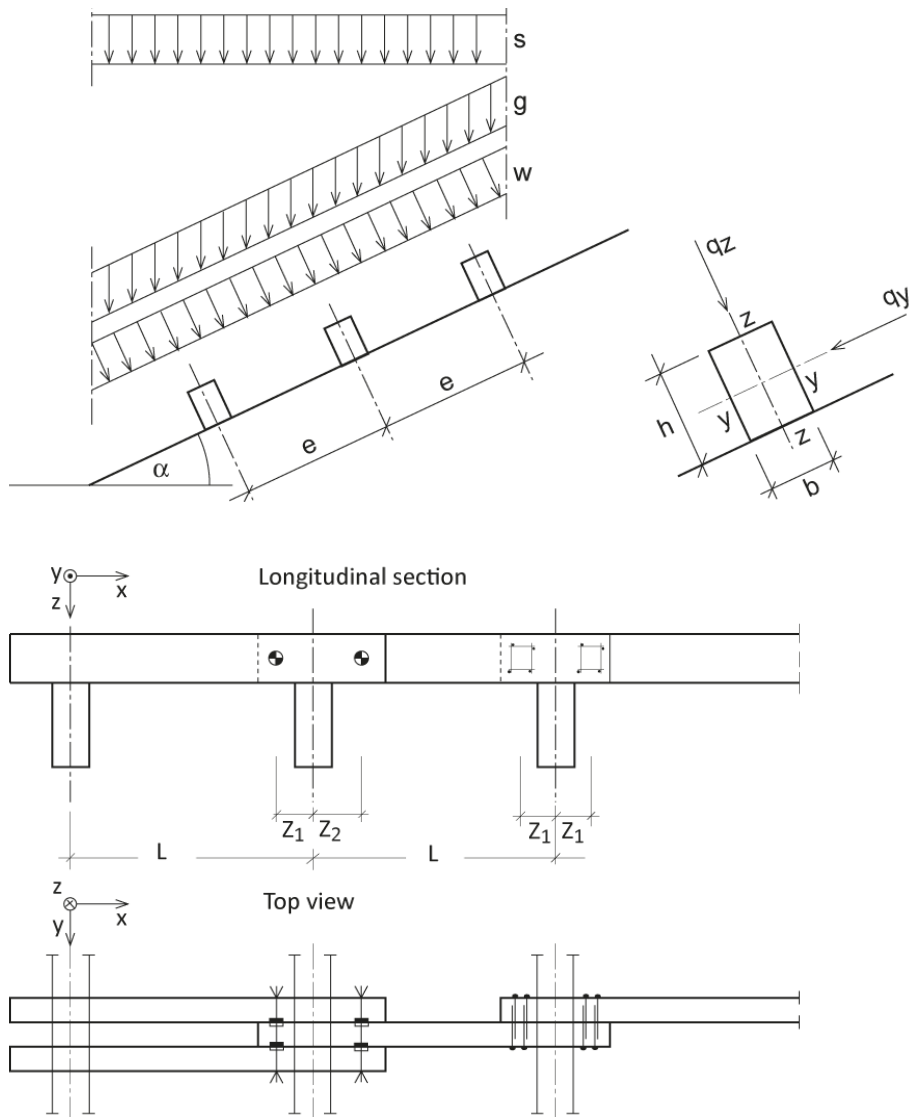

### Articulated purlin

For articulated purlins, you can choose between structural systems with equal support distances and systems with smaller end spans. The latter option offers the benefit of identical cross sections, hinge forces and hinge spacing. The first hinge can be in the first interior span or in the end span. For reasons of stability after the failure of a span, hinged spans and hingeless spans (Gerber girder) should alternate in the selected structural system.

The following fasteners are available for the design of the hinges:

- Bolts
- Special dowels

Depending on the design of the hinge additional verifications might be required.

### The following applies to all systems

All load case combinations are examined and the internal forces decisive for the design are determined.

Cross-breaking strength analyses are performed in accordance with EN 1995.

The stiffness of the fasteners in the connections is not considered in the determination of the stiffness and of the internal forces.

The deflection of articulated purlins is calculated as for a continuous beam. The stiffness of the double cross sections above the supports is not considered. According to the reference literature, this method balances out the disregard of the stiffness of the fasteners.

The purlins must be secured against tilting and uplift at the supports. A separate verification of the uplift resistance is required in the area of the intersecting building edges.

In connection with large span widths, bends could occur at the hinges and must be considered in the constructive layout of the roof skin.

## Basis of calculation

The basis of the calculation of single-span purlins, tie purlins and articulated purlins is provided by EN 1995 and its national loading regulations for EN 1990 and EN 1991.

It is assumed that the purlins are installed underneath the roof skin and are sufficiently secured against tilting and uplift at the supports.

The structural calculation of the decisive internal moments, the bearing forces, the deflections as well as the overcoupling geometry is performed with the help of coefficient tables.

Bearing stress, shear stress, tilting stability and man load resistance verifications are neglected in the cross-section design. If required, these stresses and loads must be considered in addition.

## Definition of the structural system

### Definition wizard

The wizard is automatically launched when you start the software. It supports the user in defining the most important parameters for a new item.

With the help of the wizard, you can quickly define a structural system and gain a first impression of the results. Subsequently, you can adjust secondary parameters in a second step.

*Note:* You can disable the automatic start of the wizard via the corresponding option on the bottom of the window.

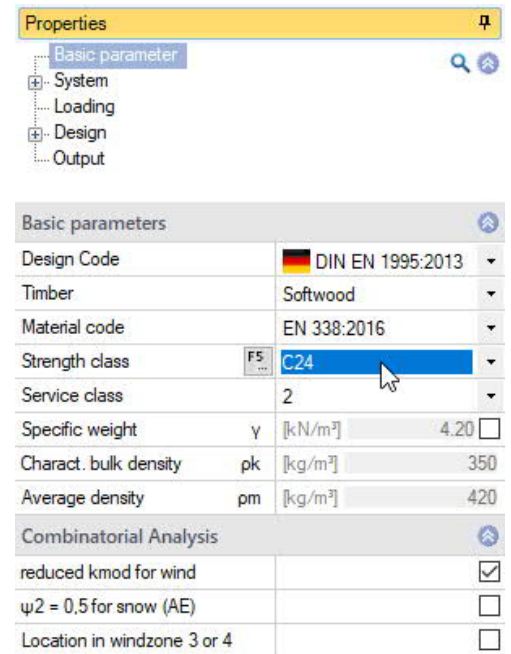

Basic parameters	
Design Code	 DIN EN 1995:2013
Timber	Softwood
Material code	EN 338:2016
Strength class	F5 ... <b>C24</b>
Service class	2
Specific weight	γ [kN/m³] 4.20
Charact. bulk density	pk [kg/m³] 350
Average density	pm [kg/m³] 420
Combinatorial Analysis	
reduced kmod for wind	<input checked="" type="checkbox"/>
ψ2 = 0.5 for snow (AE)	<input type="checkbox"/>
Location in windzone 3 or 4	<input type="checkbox"/>

### Basic parameters

Select the desired [standard](#) and the material.

Species of timber:

- Softwood
- Hardwood
- Glulam

Strength class - F5 key:

The strengths and stiffnesses can be adjusted for solid wood and glued laminated timber. To do this, click in the input field and press the F5 key. You can enter / edit / save / load new material in the "User-defined material" pop-up menu.

*Note:* Glulam implemented according to EN 14080: 2013 for Germany and Italy.  
The "old (DIN)" glued laminated timbers are marked with a \* (e.g. GL24c \*).

### Combinatorial analysis

The available selection options and data-entry fields depend on the selected standard

kmod	check this option to use the modification coefficient 'kmod' under wind action as an average value for the load duration classes 'short' and 'very short'.
ψ2	check this option to increase the value of the combination coefficient ψ2 to 0.5 in the accidental design situation under snow load. (See introductory decree of the federal states, e.g. Baden-Württemberg)
Wind zone	check this option if the building is situated in wind zone 3 or 4. In this case, you need not consider snow as an accompanying action with wind being the leading action.
Consequence class	select the consequence class to determine the partial safety factors.
Combination equation	select the equation from EN 1990 that should be used for the load combination in the permanent/transient design situation (6.10 and 6.10 a/b).

## System

Roof pitch	roof pitch $\alpha$
a	purlin spacing in the roof plane
Purlin type	- single-span purlin - tie purlin - articulated purlin
System type	- equal span lengths - smaller end spans
Hinge locations	- in interior span - in end span
Consider end span	check this option to take the end span into account in the determination of the tying/articulation points.

### Spans

Number of spans	number of spans of the rafter purlin system (up to 10)
L	length of the spans
Cross section...	enter the dimensions of the cross section, width b and height h

### Remarks

You can optionally enter comments to the system that are subsequently included in the output.  
See also [Remarks Editor](#).

### Bracing

The lateral support influences the approach of the buckling and tilting length.

Selection:

- None
- Continuous
- Mid span
- Third points
- Quarter points

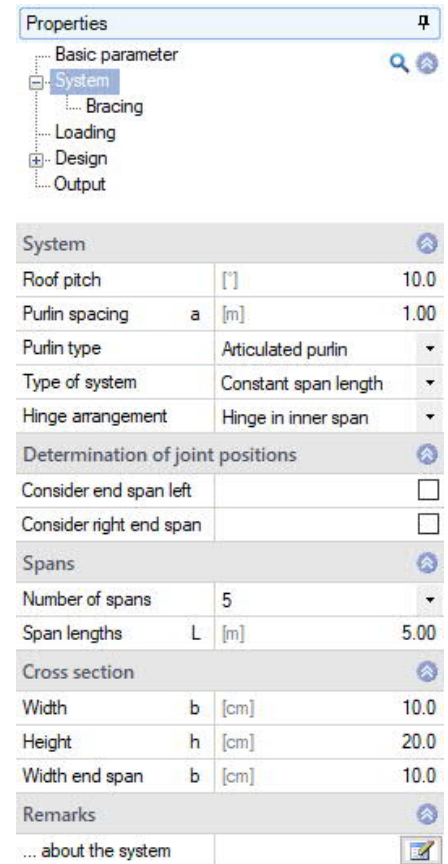

The screenshot shows the 'Properties' dialog box for the 'System' parameter. The 'System' section is expanded, showing the following settings:

System		
Roof pitch	[°]	10.0
Purlin spacing	a [m]	1.00
Purlin type	Articulated purlin	▼
Type of system	Constant span length	▼
Hinge arrangement	Hinge in inner span	▼
Determination of joint positions		
Consider end span left		<input type="checkbox"/>
Consider right end span		<input type="checkbox"/>
Spans		
Number of spans	5	▼
Span lengths	L [m]	5.00
Cross section		
Width	b [cm]	10.0
Height	h [cm]	20.0
Width end span	b [cm]	10.0
Remarks		
... about the system		

## Loading

- Self-weight Disregard/Uniformly distributed load/Exact (frame)
- Municipality Wind & Snowloadparameters. Displays a [dialog](#) allowing you to define the wind zone (by selecting a municipality in Germany) and the associated values as well as other wind and snow parameters.  
*The generated loads are added to the load list. They cannot be edited subsequently. You can delete entries from the list, however.*
- Wind zones The greatest suction and pressure values are determined from all selected areas.  
Wind directions are taken into account as follows:  
H, I, J: always all wind directions  
F, G: all wind directions  
or  
F, G: only the wind directions across the ridge (eaves / purlin)
- Accidental snow (only in comb. with DIN EN 1995): check this option to include snow as an accidental load (e.g. in the Northern Lowlands of Germany).
- Factor (only in comb. with DIN EN 1995): factor for the accidental snow load; typically, 2.3 in the Northern Lowlands of Germany

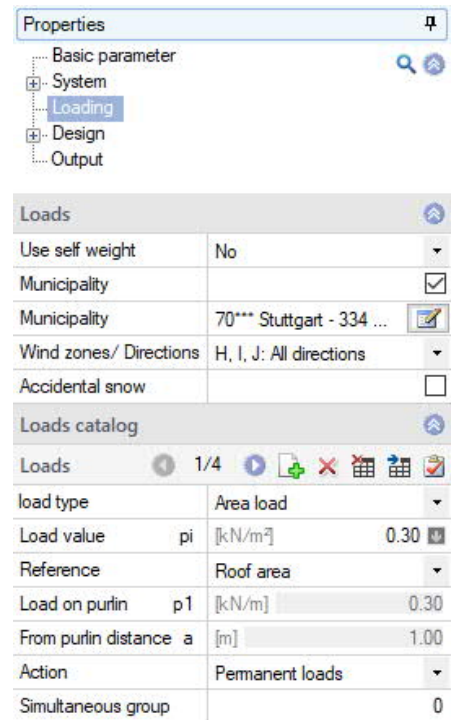

### Loads

Enter the values for the first load directly in the corresponding data-entry mask.

Add additional loads with the help of the load toolbar:



- see [Data entry via tables](#) (Basic Operating Instructions)

To add loads, always set up a new entry first by activating the button (an empty data-entry mask is displayed each time).

Alternatively, you can enter additional loads also in a well-structured load table - click on the **Loads** tab (below the graphical representation) to access the table.

- Load type Uniform line load / area load / axial force
- Last value pi Direct entry of the load value or call of the load value combination via the "arrow symbol" - see description in the program LAST+.
- Reference base area/roof area
- Action allows you to select an action that is assigned to this load: permanent, category H: roofs, wind loads, snow below/above 1,000 m altitude, permanent, removable (pv-Photovoltaics).
- Sim group Loads can be assigned to a simultaneous group. Loads related to a group (i.e. with the same group number) are always applied together.

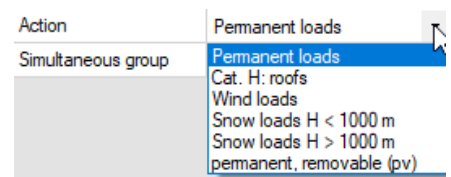

## Design

### Fasteners

The fasteners available for selection depend on the selected [type of purlin](#).

Type special dowels, nails, bolts (only in comb. with articulated purlins) / Bolts (only with coupled purlin)

If you need more information on a parameter or data-entry field, click on the field/option to display a brief help text in the lower area of the window.

Special dowels:

Dowel type: A = joint ring  
C = toothed plate

### Deformation limits

Permissible deflections

Perm. wInst permissible initial deflection  
wInst(standard) = L/300

Perm. wNetFin permissible total deflection  
wNetFin(standard) = L/300

Perm. wFin permissible final deflection  
wFin(standard) = L/200

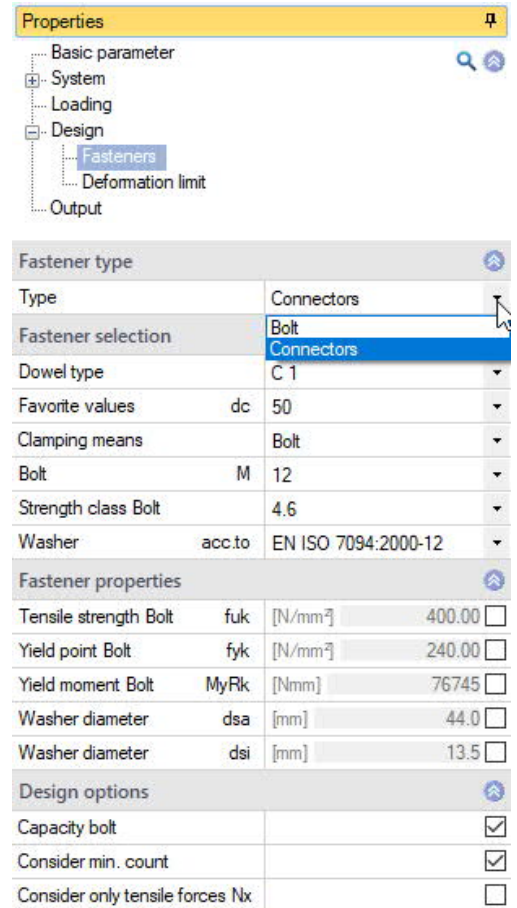

Fastener type	
Type	Connectors
Fastener selection	Bolt
Dowel type	C 1
Favorite values	dc 50
Clamping means	Bolt
Bolt	M 12
Strength class Bolt	4.6
Washer	acc.to EN ISO 7094:2000-12
Fastener properties	
Tensile strength Bolt	fuk [N/mm <sup>2</sup> ] 400.00
Yield point Bolt	fyk [N/mm <sup>2</sup> ] 240.00
Yield moment Bolt	MyRk [Nmm] 76745
Washer diameter	dsa [mm] 44.0
Washer diameter	dsi [mm] 13.5
Design options	
Capacity bolt	<input checked="" type="checkbox"/>
Consider min. count	<input checked="" type="checkbox"/>
Consider only tensile forces Nx	<input type="checkbox"/>



# Output & results

Output of system data, results and graphics on the screen or printer.  
 The different options allow you to define the scope of data to be put out.

Click on the 'Document' tab above the graphical window to display the output data in PDF format - see also [Output and printing eng.pdf](#).

## Result graphs

To display the result graphics, click on the button 'Results' in the upper toolbar:

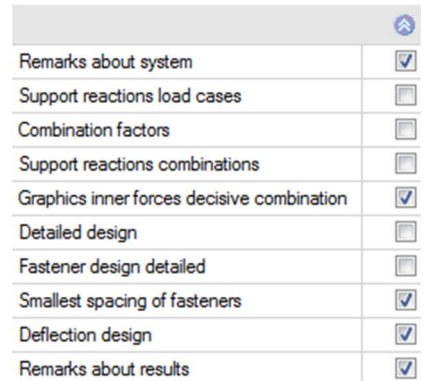
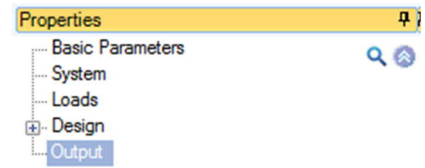
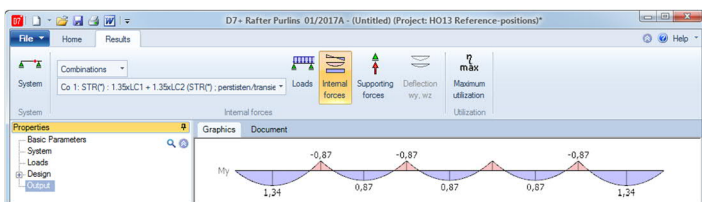

## Interface to the Continuous Beam

Single-span and tie purlins can be transferred to the program Continuous Beam DLT via the "Associated Programs" button.

Other interfaces with system and / or load transfer:

Continuous Beam Timber HTM+, Toolbox-HHP, Glued Laminated Girder D10+, Timber Column HO1+, Purlin and Rafter Roof D11

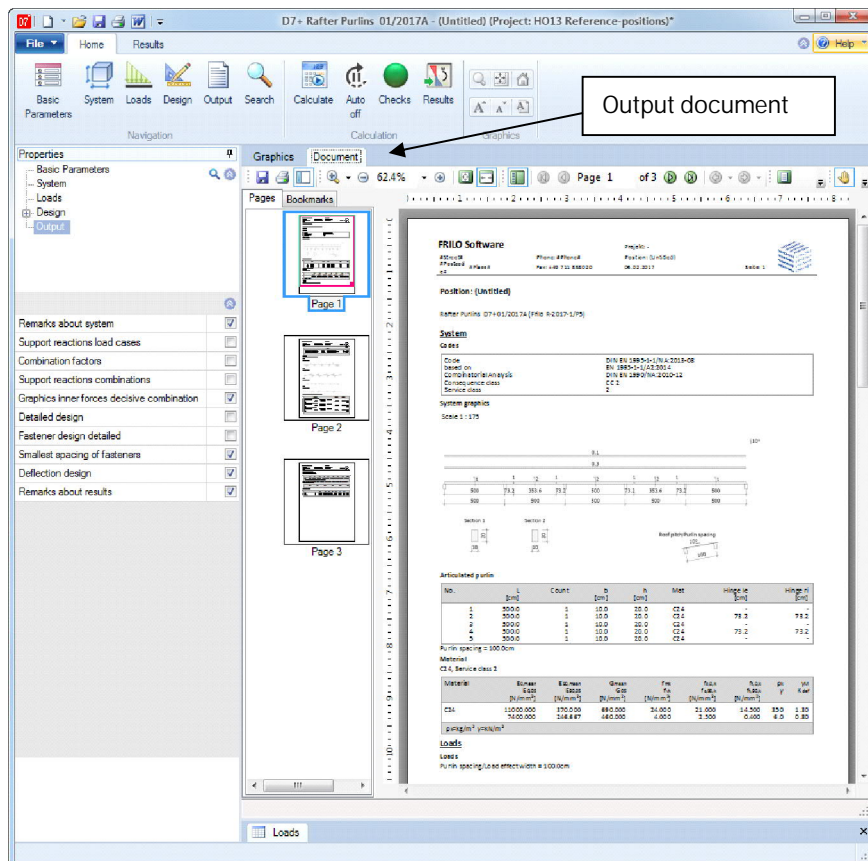
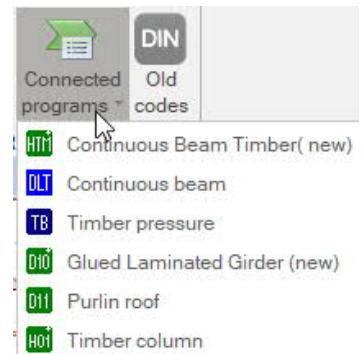

## Reference literature

- /1/ Ehlbeck, J. und Siebert, W.: Tragverhalten von Nagelverbindungen bei gleichzeitiger Beanspruchung auf Abscheren und Herausziehen. Research report on behalf of the Federal Ministry for Regional Planning, Building and Urban Development, can be obtained from Informationszentrum Raum und Bau of the Fraunhofer-Gesellschaft, Nobelstr. 12, 7000 Stuttgart 80, Tel.: +49 (0)711/6868-500
- /2/ Brüninghoff, H. und Probst, T.: Genagelte Koppelpfetten mit glattschaftigen Nägeln nach DIN 1151. Research report on behalf of the Entwicklungsgemeinschaft Holzbau. Holzwirtschaftlicher Verlag der Arbeitsgemeinschaft Holz e.V., Düsseldorf 1986
- /3/ Holzbau-Statistische Berechnungen Part 1, Holzwirtschaftlicher Verlag der Arbeitsgemeinschaft Holz e.V., Düsseldorf 1988
- /4/ Werner, G.: Holzbau Teil2: Dach- und Hallentragwerke. Werner-Verlag, Düsseldorf, 1982
- /5/ DIN 1052:2004/2008
- /6/ EN 1995:2004/2008